



OSHA 1926.502
OSHA 1910.140

PERIMETER LIMITER

Counterweight Fall Arrest System



Fall Protection

USER INSTRUCTIONS

5902381 REV. D

1

2100090

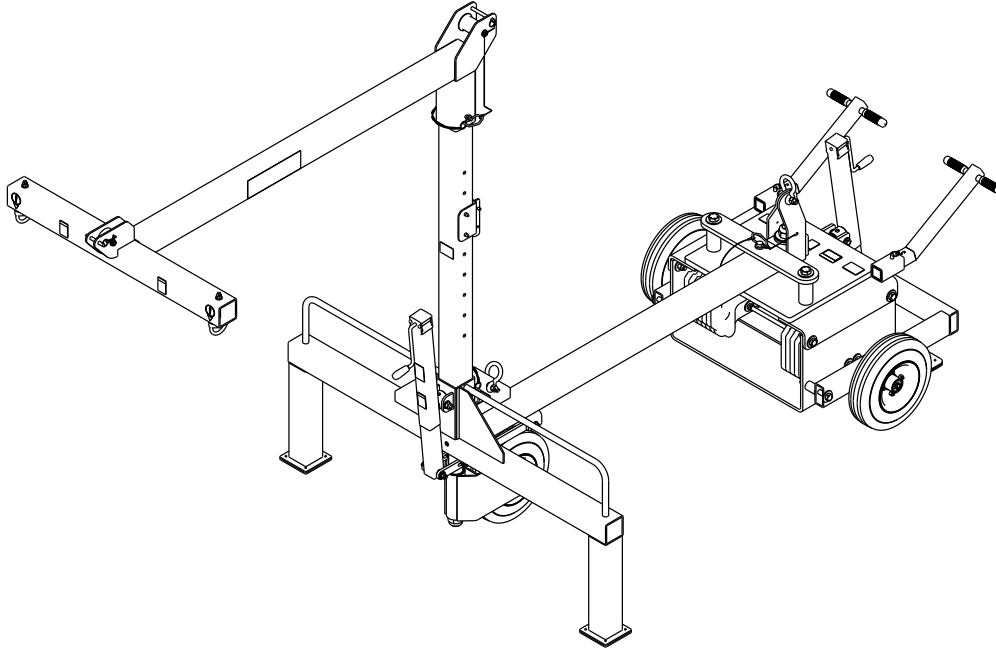

2

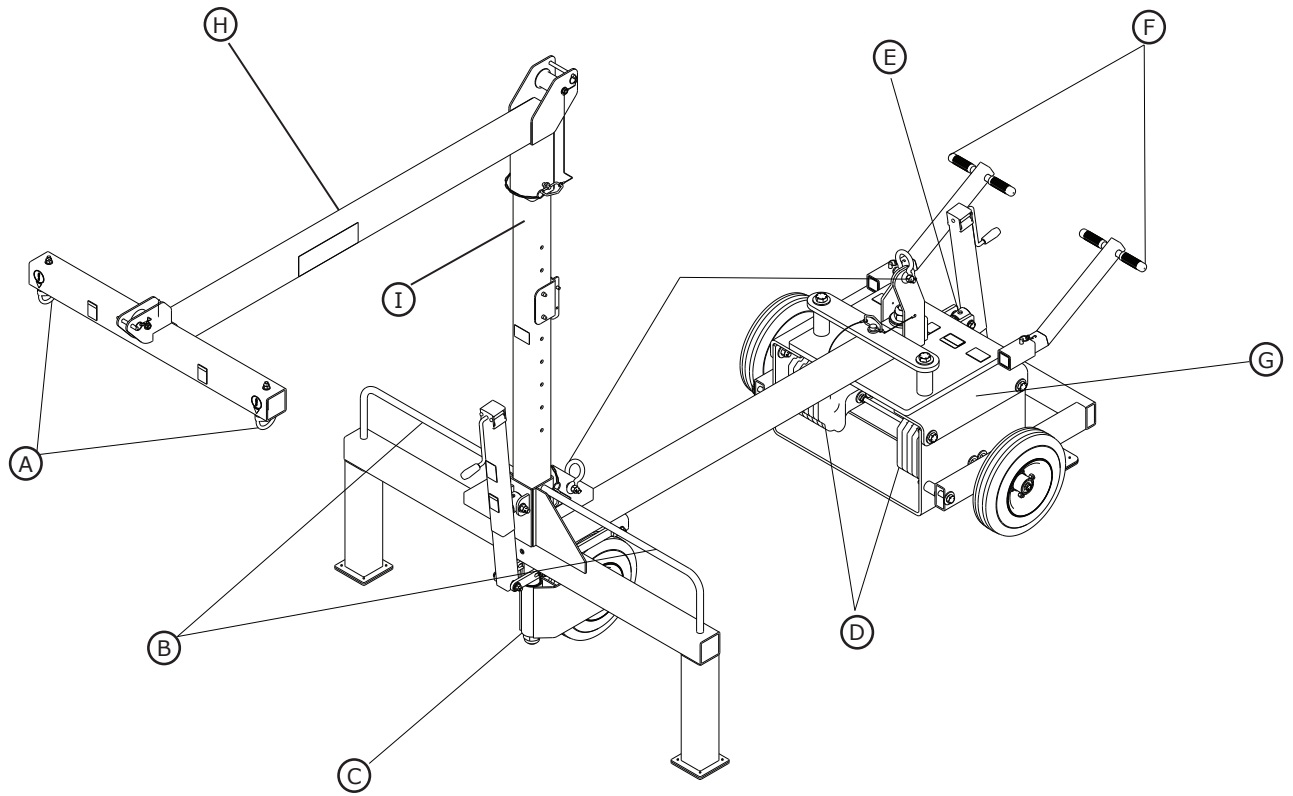

3

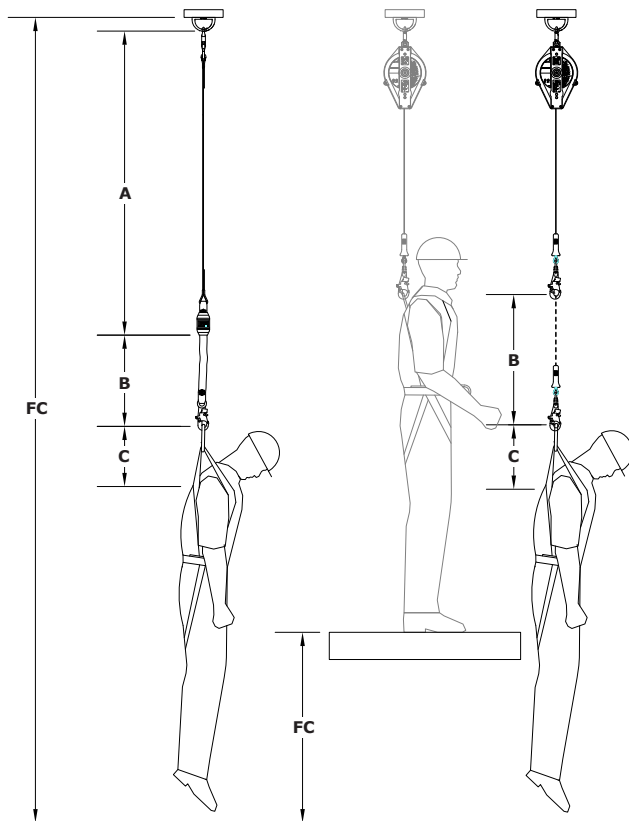

4

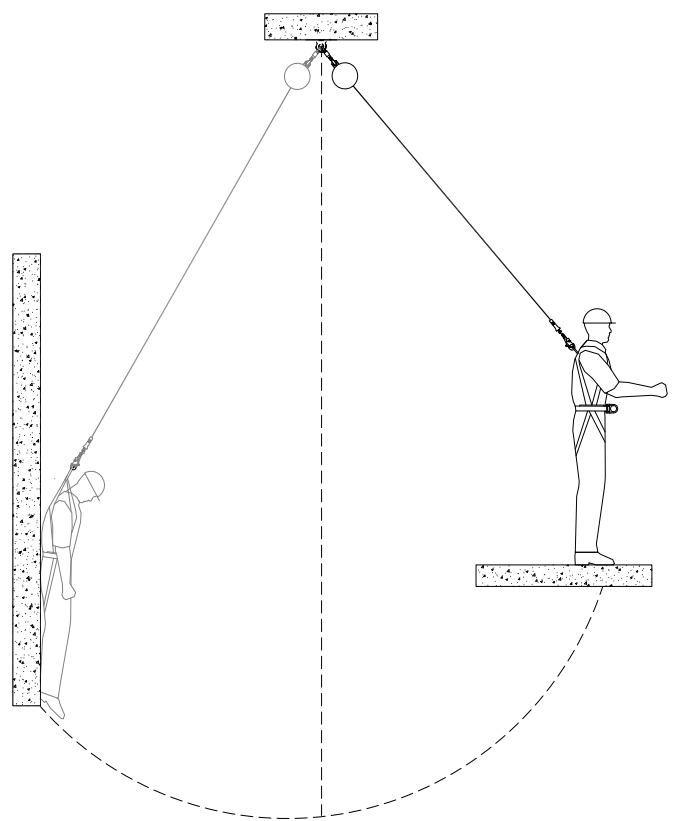

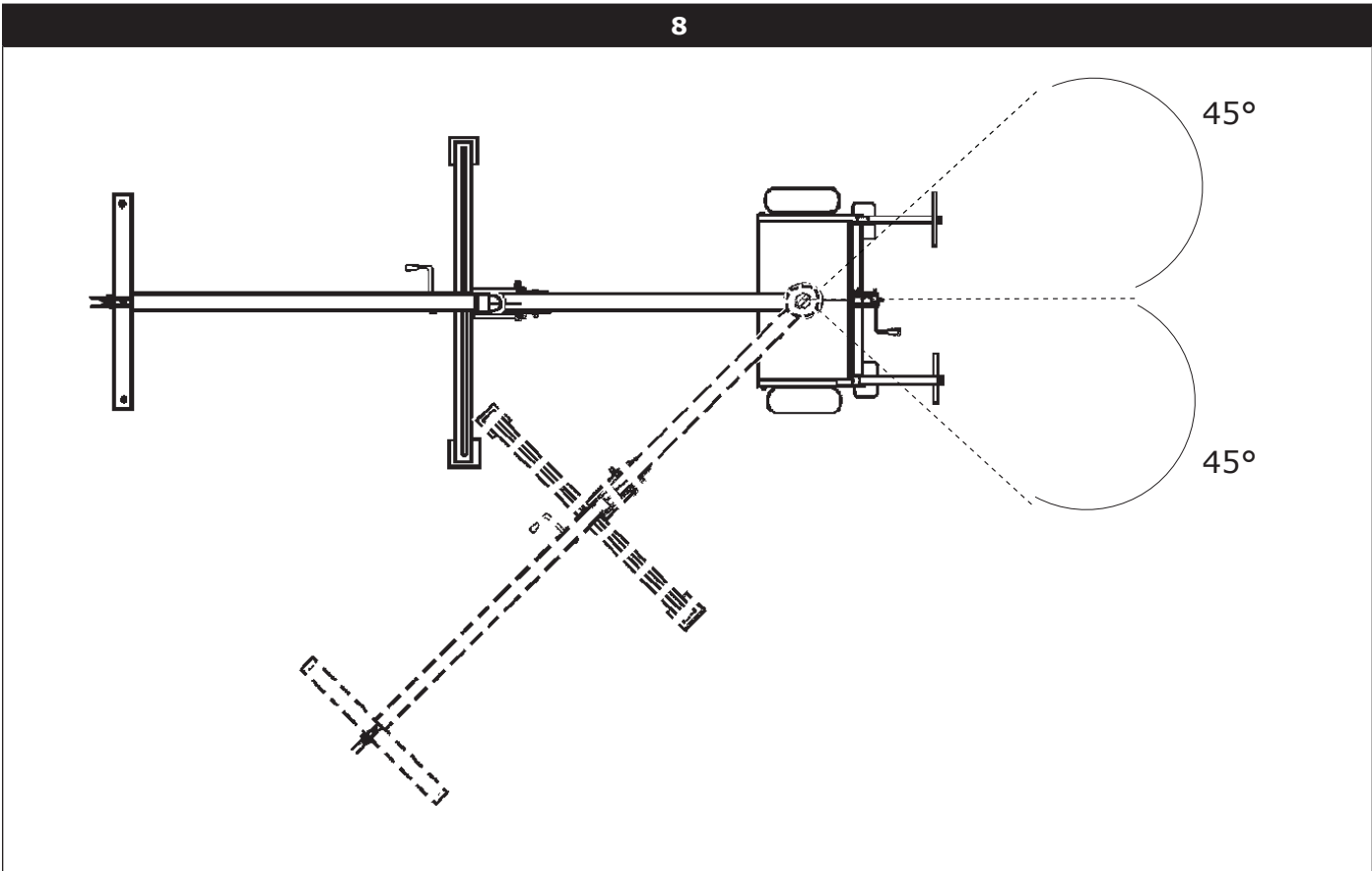
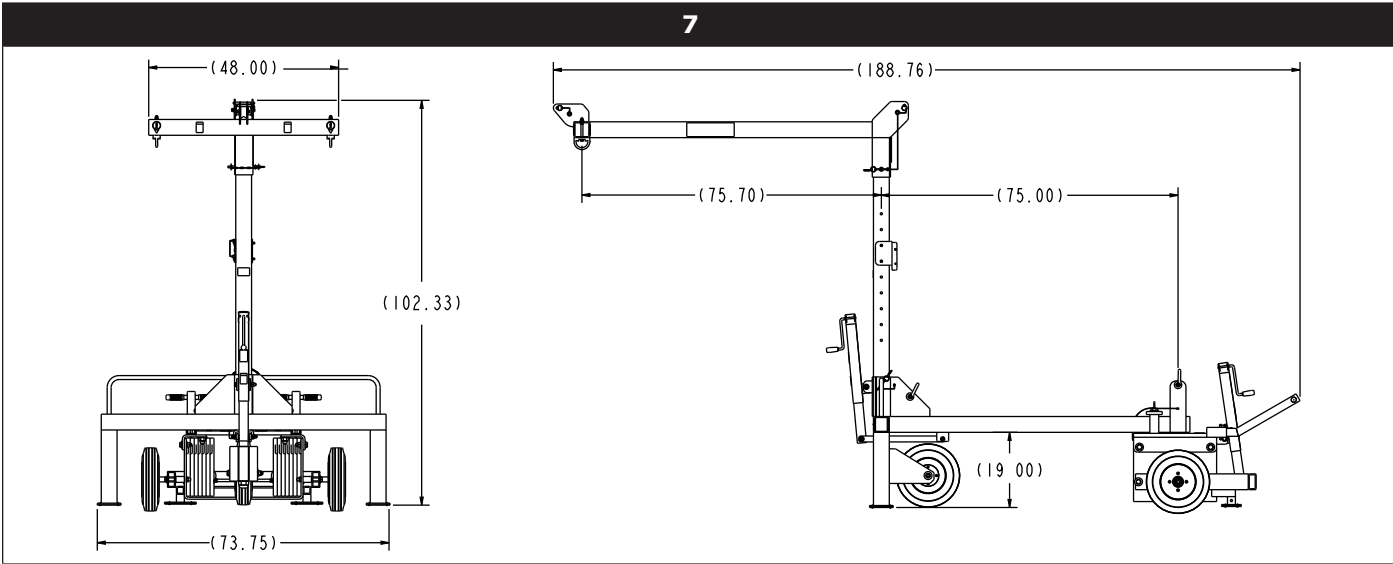
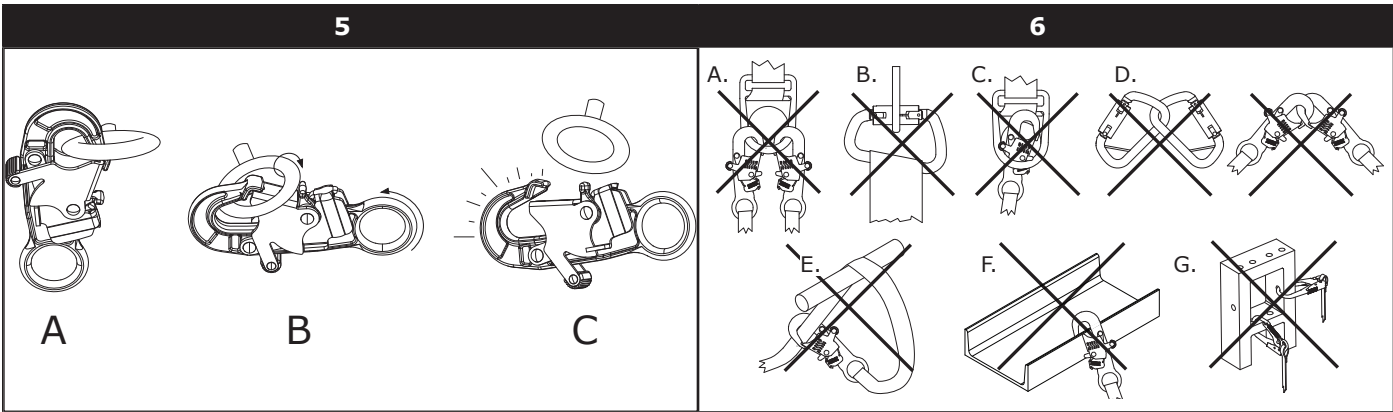

9

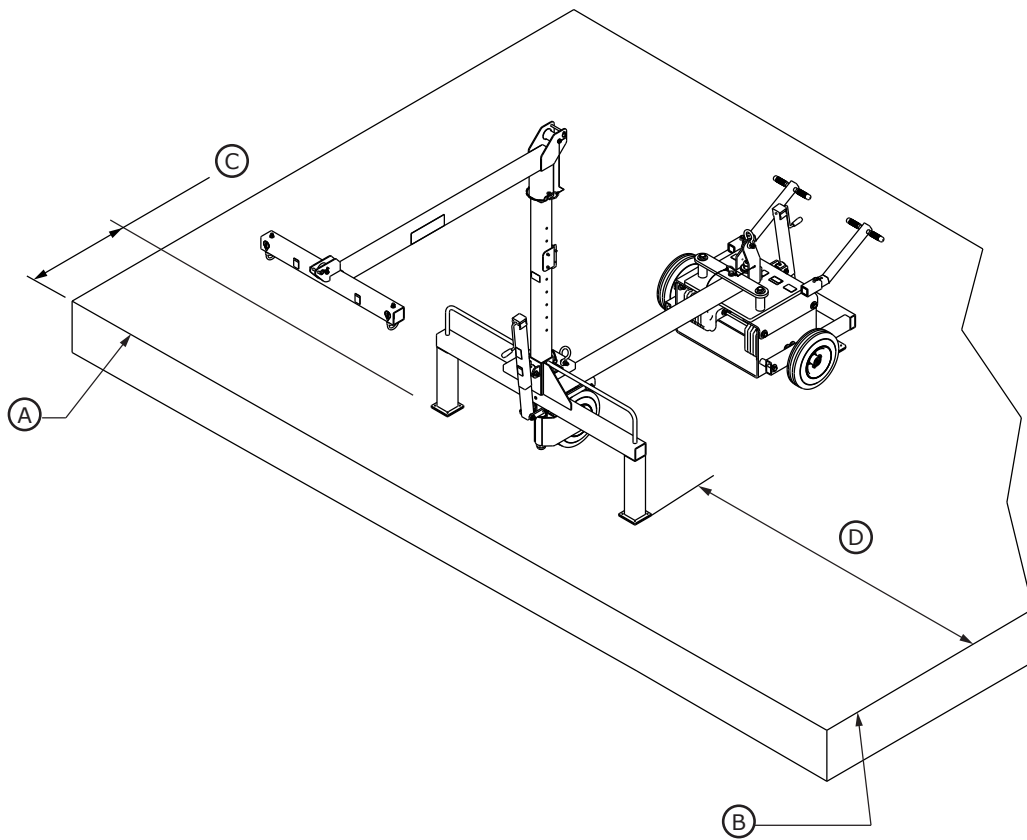

10

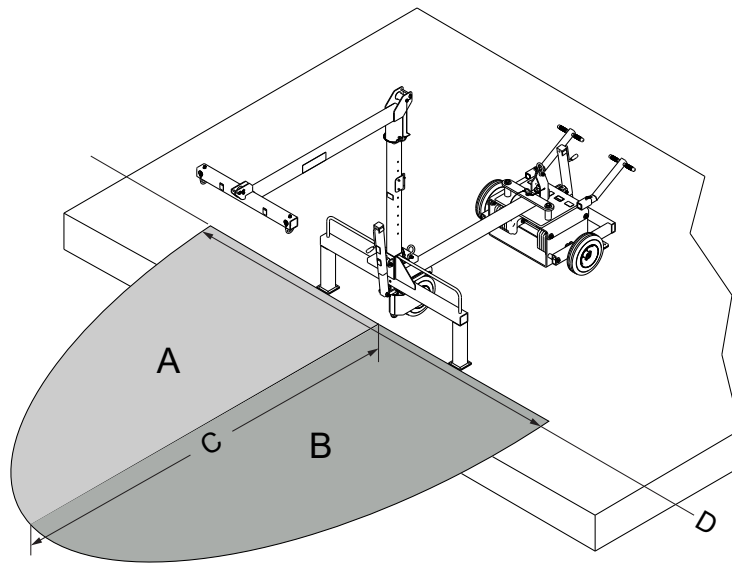

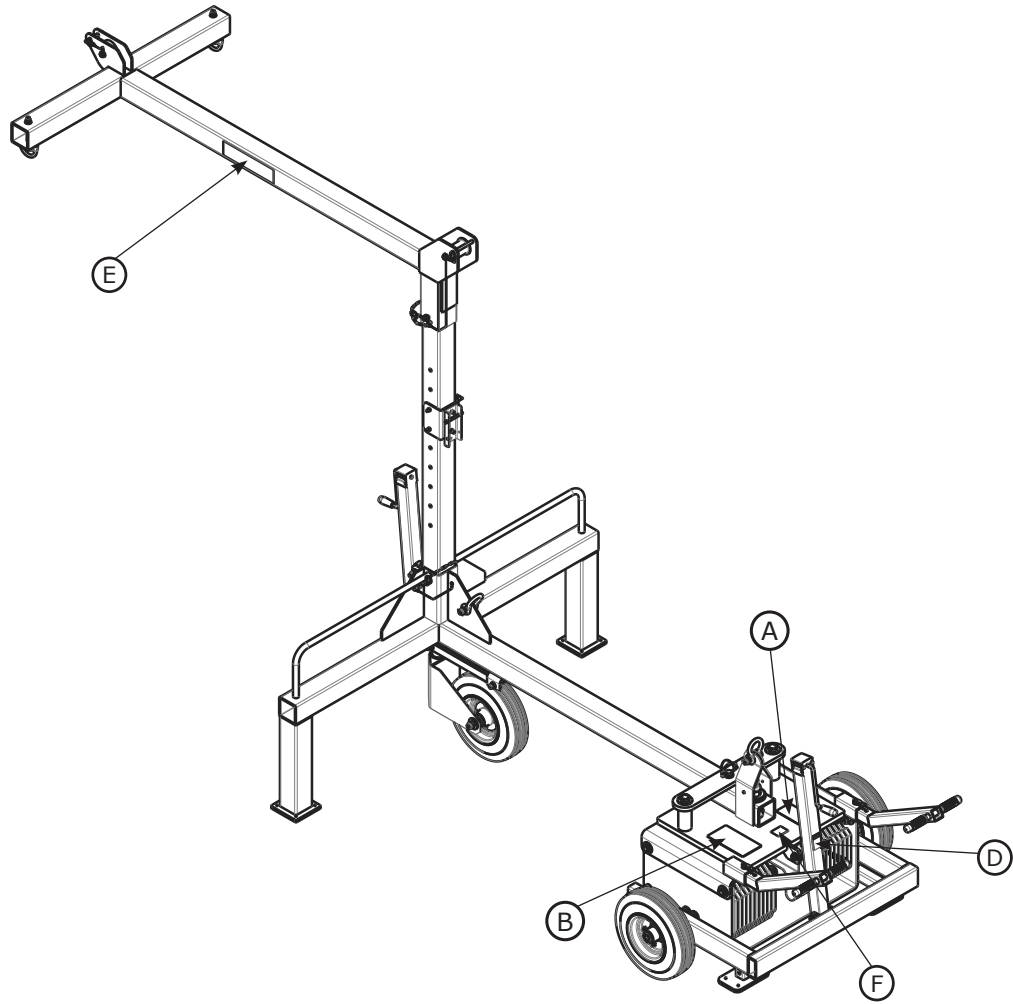

(A)

<input checked="" type="checkbox"/>		
XX / XX	20XX	ABC
	20__	
	20__	
	20__	
	20__	
	20__	
	20__	
	20__	
	20__	
	20__	
	20__	
	20__	

(B)

3M **SALA**

≤ 310 lbs. (140 kg) + ≤ 310 lbs. (140 kg)

OSHA
1926.502 / 1910.140

≤ 1,350 lb. (6 kN) MAF & ≤ 900 lb. (4 kN) AAF

Diagrams showing equipment use with dimensions: 2' (0.61m), 3' (0.91m), 24" (7.31m), 20" (50.8cm).

(C)

⚠ WARNING

**DO NOT USE!
FOR SHIPPING
PURPOSES ONLY.
REMOVE AND
DISCARD BEFORE
USE.**

9513973 Rev. A

(D)

⚠

⚡

9508074 Rev. A

(E)

3M | **DBI SALA**
Flexiguard™ Solutions

9513973 Rev. A

(F)

3M | **DBI SALA**

Mfrd. (yr, mo) Model No.:
Fabr. (aa, mm) N° de Modelo:

3M.com/FallProtection
Red Wing, MN 55066, USA

Serial no / N° de serie: 9514429 Rev. B

SAFETY INFORMATION

Please read, understand, and follow all safety information contained in these instructions prior to the use of this Anchorage Connector. **FAILURE TO DO SO COULD RESULT IN SERIOUS INJURY OR DEATH.**

These instructions must be provided to the user of this equipment. Retain these instructions for future reference.

Intended Use:

This Anchorage Connector is intended for use as part of a complete personal fall protection system.

Use in any other application including, but not limited to, material handling, recreational or sports related activities, or other activities not described in the User Instructions, is not approved by 3M and could result in serious injury or death.

This device is only to be used by trained users in workplace applications.

WARNING

This Anchorage Connector is part of a personal fall protection system. It is expected that all users be fully trained in the safe installation and operation of their personal fall protection system. **Misuse of this device could result in serious injury or death.** For proper selection, operation, installation, maintenance, and service, refer to these User Instructions and all manufacturer recommendations, see your supervisor, or contact 3M Technical Service.

- **To reduce the risks associated with working with an Anchorage Connector which, if not avoided, could result in serious injury or death:**
 - Inspect the device before each use, at least annually, and after any fall event. Inspect in accordance with the User Instructions.
 - If inspection reveals an unsafe or defective condition, remove the device from service and repair or replace according to the User Instructions.
 - Any device that has been subject to fall arrest or impact force must be immediately removed from service and destroyed.
 - The device must only be installed in the specified substrates or on structures detailed in the User Instructions. Installations and use outside the scope of this instruction must be approved by 3M Fall Protection.
 - The substrate or structure to which the anchorage connector is attached must be able to sustain the static loads specified for the anchor in the orientations permitted in the User Instructions.
 - Only connect other fall protection subsystems to the designated anchorage connection point on the device.
 - Prior to drilling or fastening, ensure no electric lines, gas lines, or other critical embedded systems will be contacted by the drill or the device.
 - Ensure that fall protection systems/subsystems assembled from components made by different manufacturers are compatible and meet the requirements of applicable standards, including the ANSI Z359 or other applicable fall protection codes, standards, or requirements. Always consult a Competent or Qualified Person before using these systems.
 - (TIE-OFF ADAPTERS) Ensure the tie-off adapter device is tight against the anchoring structure. Never leave slack in the tie-off adapter device.
- **To reduce the risks associated with working at height which, if not avoided, could result in serious injury or death:**
 - Ensure your health and physical condition allow you to safely withstand all of the forces associated with working at height. Consult with your doctor if you have any questions regarding your ability to use this equipment.
 - Never exceed allowable capacity of your fall protection equipment.
 - Never exceed maximum free fall distance of your fall protection equipment.
 - Do not use any fall protection equipment that fails pre-use or other scheduled inspections, or if you have concerns about the use or suitability of the equipment for your application. Contact 3M Technical Services with any questions.
 - Some subsystem and component combinations may interfere with the operation of this equipment. Only use compatible connections. Consult 3M prior to using this equipment in combination with components or subsystems other than those described in the User Instructions.
 - Use extra precautions when working around moving machinery (e.g. top drive of oil rigs) electrical hazards, extreme temperatures, chemical hazards, explosive or toxic gases, sharp edges, or below overhead materials that could fall onto you or your fall protection equipment.
 - Use Arc Flash or Hot Works devices when working in high heat environments.
 - Avoid surfaces and objects that can damage the user or equipment.
 - Ensure there is adequate fall clearance when working at height.
 - Never modify or alter your fall protection equipment. Only 3M or parties authorized in writing by 3M may make repairs to the equipment.
 - Prior to use of fall protection equipment, ensure a rescue plan is in place which allows for prompt rescue if a fall incident occurs.
 - If a fall incident occurs, immediately seek medical attention for the worker who has fallen.
 - Do not use a body belt for fall arrest applications. Use only a Full Body Harness.
 - Minimize swing falls by working as directly below the anchorage point as possible.
 - If training with this device, a secondary fall protection system must be utilized in a manner that does not expose the trainee to an unintended fall hazard.
 - Always wear appropriate personal protective equipment when installing, using, or inspecting the device/system.

Prior to installation and use of this equipment, record the product identification information from the ID label in the Inspection and Maintenance Log (Table 2) at the back of this manual.

PRODUCT DESCRIPTION:

Figure 1 illustrates the assembled 3M™ DBI-SALA™ Perimeter Limiter System. It is used as an anchorage for a Personal Fall Arrest System (PFAS) for a person working on form work, flat roofs, or similar structures.

Figure 2 illustrates components of the Perimeter Limiter. See Table 1 for Component Specifications.

Table 1 – Specifications

System Specifications:		
Capacity:	1 Person with a combined weight (clothing, tools, etc.) of no more than 310 lbs (141 kg) ¹ .	
Resting Structure Requirements:	The surface on which the Perimeter Limiter is installed must be capable of supporting the maximum vertical load of 3,815 lbs (1,730 kg).	
Arresting Force:	All connecting subsystems (SRDs, Energy-Absorbing Lanyards, etc.) used with the Perimeter Limiter must limit Arresting Force to the following values, as determined by the applicable standard:	
	Applicable Standards	Maximum Arresting Force
	OSHA	1,350 lbf (6.0 kN)
	Average Arresting Force	900 lbf (4.0 kN)
Dimensions:	See Figure 7	
Product Weight:	2,015 lb. (914 kg)	
Standards:	Meets the test requirements of OSHA 1926.502 and 1910.140	
Component Specifications:		
Figure 2 Reference	Component	Materials
(A)	Anchor Points	Zinc Plated Steel
(B)	Positioning Bars	Powder Coated Steel
(C)	Front Foot Pad Jack	Steel
(D)	Additional Weights (Optional)	Steel
(E)	Rear Foot Pad Jack	Steel
(F)	Positioning Handles	Plastic
(G)	Weight Cart	Powder Coated Steel
(H)	Mast Arm	Powder Coated Steel
(I)	Mast	Powder Coated Steel

1 Capacity: 310 lbs (141 kg) is the capacity range required by ANSI. This product has been tested to a 420 lbs (191 kg) Maximum Capacity per OSHA.

2 Qualified Person: An individual with a recognized degree or professional certificate, and extensive experience in Fall Protection. This individual must be capable of design, analysis, evaluation, and specification in Fall Protection.

1.0 PRODUCT APPLICATION

- 1.1 PURPOSE:** Anchorage Connectors are designed to provide anchorage connection points for Fall Arrest¹, Fall Restraint², Work Positioning³, or Rescue⁴ systems.

Fall Protection Only: This Anchorage Connector is for connection of Fall Protection Equipment. Do not connect Lifting Equipment to the Anchorage Connector.

- 1.2 STANDARDS:** Your Anchorage Connector conforms to the national or regional standard(s) identified on the front cover of these instructions. If this product is resold outside the original country of destination, the re-seller must provide these instructions in the language of the country in which the product will be used.
- 1.3 SUPERVISION:** Use of this equipment must be supervised by a Competent Person⁵.
- 1.4 TRAINING:** This equipment must be installed and used by persons trained in its correct application. This manual is to be used as part of an employee training program as required by ANSI and OSHA, and/or regional regulations. It is the responsibility of the users and installers of this equipment to ensure they are familiar with these instructions, trained in the correct care and use of this equipment, and are aware of the operating characteristics, application limitations, and consequences of improper use of this equipment.
- 1.5 RESCUE PLAN:** When using this equipment and connecting subsystem(s), the employer must have a rescue plan and the means at hand to implement and communicate that plan to users, authorized persons⁶, and rescuers⁷. A trained, on-site rescue team is recommended. Team members should be provided with the equipment and techniques to perform a successful rescue. Training should be provided on a periodic basis to ensure rescuer proficiency.

2.0 SYSTEM REQUIREMENTS

- 2.1 ANCHORAGE:** Anchorage requirements vary with the fall protection application. Structure on which the Anchorage Connector is placed or mounted must meet the Anchorage specifications defined in Table 1.
- 2.2 PERSONAL FALL ARREST SYSTEM:** Figure 1 illustrates the application of this Anchorage Connector. Personal Fall Arrest Systems (PFAS) used with the system must meet applicable Fall Protection standards, codes, and requirements. The PFAS must incorporate a Full Body Harness and limit Arresting Force to the values defined in Table 1.
- 2.3 FALL PATH AND SRD LOCKING SPEED:** A clear path is required to assure positive locking of an SRD. Situations which do not allow for an unobstructed fall path should be avoided. Working in confined or cramped spaces may not allow the body to reach sufficient speed to cause the SRD to lock if a fall occurs. Working on slowly shifting material, such as sand or grain, may not allow enough speed buildup to cause the SRD to lock.
- 2.4 HAZARDS:** Use of this equipment in areas with environmental hazards may require additional precautions to prevent injury to the user or damage to the equipment. Hazards may include, but are not limited to: heat, chemicals, corrosive environments, high voltage power lines, explosive or toxic gases, moving machinery, sharp edges, or overhead materials that may fall and contact the user or Personal Fall Arrest System.
- 2.5 FALL CLEARANCE:** Figure 4 illustrates the components of a Fall Arrest. There must be sufficient Fall Clearance (FC) to arrest a fall before the user strikes the ground or other obstruction. Clearance is affected by a number of factors including: Anchorage Location, (A) Lanyard Length, (B) Lanyard Deceleration Distance or SRD Maximum Arrest Distance, (C) Harness Stretch and D-Ring/Connector Length and Settling. Refer to the instructions included with your Fall Arrest subsystem for specifics regarding Fall Clearance calculation.
- 2.6 SWING FALLS:** Swing Falls occur when the anchorage point is not directly above the point where a fall occurs (see Figure 5). The force of striking an object in a swing fall may cause serious injury or death. Minimize swing falls by working as directly below the anchorage point as possible. Do not permit a swing fall if injury could occur. Swing falls will significantly increase the clearance required when a Self-Retracting Device or other variable length connecting subsystem is used.
- 2.7 COMPONENT COMPATIBILITY:** 3M equipment is designed for use with 3M approved components and subsystems only. Substitutions or replacements made with non-approved components or subsystems may jeopardize compatibility of equipment and may affect the safety and reliability of the complete system.
- 2.8 CONNECTOR COMPATIBILITY:** Connectors are considered to be compatible with connecting elements when they have been designed to work together in such a way that their sizes and shapes do not cause their gate mechanisms to inadvertently open regardless of how they become oriented. Contact 3M if you have any questions about compatibility. Connectors (hooks, carabiners, and D-rings) must be capable of supporting at least 5,000 lbs. (22.2 kN). Connectors must be compatible with the anchorage or other system components. Do not use equipment that is not compatible. Non-compatible connectors may unintentionally disengage (see Figure 6). Connectors must be compatible in size, shape, and strength. If the connecting element to which a snap hook or carabiner attaches is undersized or irregular in shape, a situation could occur where the connecting element applies a force to the gate of the snap hook or carabiner (A). This force may cause the gate to open (B), allowing the snap hook or carabiner to disengage from the connecting point (C).
- Self-locking snap hooks and carabiners are required by ANSI Z359 and OSHA.
- 2.9 MAKING CONNECTIONS:** Snap hooks and carabiners used with this equipment must be self-locking. Ensure all connections are compatible in size, shape and strength. Do not use equipment that is not compatible. Ensure all

1 Fall Arrest System: A collection of Fall Protection Equipment configured to arrest a free fall. Protects the user in the event of a fall. Free fall is permitted up to the limits allowed by the connecting device (either an Energy Absorbing Lanyard or Self-Retracting Device (SRD)).

2 Restraint System: A collection of Fall Protection Equipment configured to prevent the person's center of gravity from reaching a fall hazard. Prevents the user from reaching a hazard. No vertical free fall is permitted.

connectors are fully closed and locked.

3M connectors (snap hooks and carabiners) are designed to be used only as specified in each product's user's instructions. See Figure 7 for examples of inappropriate connections. Do not connect snap hooks and carabiners:

- A. To a D-ring to which another connector is attached.
- B. In a manner that would result in a load on the gate. Large throat snap hooks should not be connected to standard size D-rings or similar objects which will result in a load on the gate if the hook or D-ring twists or rotates, unless the snap hook complies is equipped with a 3,600 lb (16 kN) gate. Check the marking on your snap hook to verify that it is appropriate for your application.
- C. In a false engagement, where features that protrude from the snap hook or carabiner catch on the anchor, and without visual confirmation seems to be fully engaged to the anchor point.
- D. To each other.
- E. Directly to webbing or rope lanyard or tie-back (unless the manufacturer's instructions for both the lanyard and connector specifically allows such a connection).
- F. To any object which is shaped or dimensioned such that the snap hook or carabiner will not close and lock, or that roll-out could occur.
- G. In a manner that does not allow the connector to align properly while under load.

3.0 INSTALLATION

Installation of the DBI-SALA Perimeter Limiter must be supervised by a Qualified Person¹. The installation must be certified by a Competent Person² as meeting the criteria for a Certified Anchorage, or that it is capable of supporting the potential forces that could be encountered during a fall.

3.1 PLANNING: Plan your fall protection system prior to installation of the Perimeter Limiter. Account for all factors that may affect your safety before, during and after a fall. Consider all requirements, limitations, and specifications defined in Section 2 and Table 1.

3.2 INSTALLING THE PERIMETER LIMITER: The Perimeter Limiter is shipped with the Mast Arm installed backwards and with a smaller Mast for shipping purposes only. To install the Perimeter Limiter:

1. Remove the Mast Arm from the temporary shipping Mast.
2. Remove and discard the shipping Mast.
3. Install the Mast that was shipped loose and install the Mast Arm on the new Mast in the correct orientation shown in Figure 1.
4. Replace all pins before use.
5. Use the positioning handles on the rear of the weight cart and positioning bars on the front of the unit to position the unit at the desired work location.
6. Once the unit is in proper position and alignment, raise the front and rear tire jacks until the foot pads reach the work surface. Continue to rotate the jack handles until all three wheels are lifted off the work surface and rotate freely to ensure the weight of the unit is transferred to the foot pads.
7. Attach your personal fall arrest system (PFAS) to the attachments points on the mast arm (see Figure 1). Refer to the PFAS manufacturer's instructions for correct attachment and use of the PFAS. Do not attach more than one PFAS to an attachment point. Do not attach more than two PFAS to the Perimeter Limiter.

Do not use the system with the temporary shipping Mast installed. Remove, replace, and discard the temporary Mast before use.

4.0 USE

4.1 BEFORE EACH USE: Verify that your work area and Personal Fall Arrest System (PFAS) meet all criteria defined in Section 2 and a formal Rescue Plan is in place. Inspect the Perimeter Limiter per the 'User' inspection points defined on the "Inspection and Maintenance Log" (Table 2). If inspection reveals an unsafe or defective condition, do not use the system. Remove the system from service and destroy, or contact 3M regarding replacement or repair.

4.2 FALL ARREST CONNECTIONS: The Perimeter Limiter is used with a Full Body Harness and Energy Absorbing Lanyard or Self-Retracting Device (SRD).

4.3 LOCATION: See Figure 9. The Perimeter Limiter must be located a sufficient distance from the edge of a working surface. Minimum distance allowed is 2 ft. (0.6 m) from the front (A) of the unit and 3 ft. (0.9 m) from the side (B) of the unit.

4.4 SAFE WORK ZONE: See Figure 10. A: User 1 safe working zone, B: User 2 safe working zone, C: 26' maximum, D: 24' maximum work zone. Always work within the safe work zone of the Perimeter Limiter to avoid rocking or tipping the unit.

- Do not work above the surface level.
- Avoid working where the line may cross or tangle within another object or worker.
- Avoid slack line.
- Use shackles located on the gusset at the mast base and on the top center of the weight cart for lifting the unit to the work area. Always use both shackles when lifting unit.

5.0 INSPECTION

5.1 INSPECTION FREQUENCY: The Perimeter Limiter must be inspected at the intervals defined in Section 1. Inspection procedures are described in the "Inspection and Maintenance Log" (Table 2). Inspect all other components of the Fall Protection System per the frequencies and procedures defined in the manufacturer's instructions.

Perimeter Limiters are equipped with a Radio Frequency Identification (RFID) Tag. The RFID Tag can be used in conjunction with a Handheld Reading Device to simplify inspection and inventory control and provide records for your fall protection equipment.

5.2 DEFECTS: If inspection reveals an unsafe or defective condition, remove the Perimeter Limiter from service immediately and contact 3M regarding replacement or repair. Do not attempt to repair the Fall Arrest System.

Authorized Repairs Only: Only 3M or parties authorized in writing may make repairs to this equipment.

5.3 PRODUCT LIFE: The functional life of the Fall Arrest System is determined by work conditions and maintenance. As long as the product passes inspection criteria, it may remain in service.

6.0 MAINTENANCE, SERVICING, STORAGE

6.1 CLEANING: Periodically clean the Perimeter Limiters’s metal components with a soft brush, warm water, and a mild soap solution. Ensure parts are thoroughly rinsed with clean water.

6.2 SERVICE: Only 3M or parties authorized in writing by 3M may make repairs to this equipment. If the Perimeter Limiter has been subject to fall force or inspection reveals an unsafe or defective conditions, remove the system from service and contact 3M regarding replacement or repair.

6.3 STORAGE AND TRANSPORT: When not in use, store and transport the Fixed Beam Anchor and associated fall protection equipment in a cool, dry, clean environment out of direct sunlight. Avoid areas where chemical vapors may exist. Thoroughly inspect components after extended storage.

7.0 LABELS

Figure 11 illustrates labels on the Perimeter Limeter. Labels must be replaced if they are not fully legible. Information provided on each label is as follows:

(A)	Alteration or misuse of this product or failure to follow instructions may result in serious injury or death.
(B)	Safe Work Zone Warnings
(C)	Shipping Purposes Only
(D)	Electrocution Hazards
(E)	Flexiguard Logo Label
(F)	MFRD (Y/M), LOT Number, Model Number, Length.

Table 2 – Inspection and Maintenance Log

Inspection Date:		Inspected By:	
Components:	Inspection: (See Section 1 for <i>Inspection Frequency</i>)	User	Competent Person¹
Perimeter Limiter (Figure 2)	Inspect the Perimeter Limiter for damage: Look for cracks, dents, or deformities.	<input type="checkbox"/>	<input type="checkbox"/>
	Inspect the entire unit for corrosion.	<input type="checkbox"/>	<input type="checkbox"/>
Labels (Figure 11)	Verify that all labels are securely attached and are legible (see ' <i>Labels</i> ')	<input type="checkbox"/>	<input type="checkbox"/>
PFAS and Other Equipment	Additional Personal Fall Arrest System (PFAS) equipment (harness, SRL, etc) that are used with the Flexiguard Anchorage System should be installed and inspected per the manufacturer's instructions.	<input type="checkbox"/>	<input type="checkbox"/>

Serial Number(s):	Date Purchased:
Model Number:	Date of First Use:

Corrective Action/Maintenance:	Approved By:	Next inspection due:
	Date:	
Corrective Action/Maintenance:	Approved By:	Next inspection due:
	Date:	
Corrective Action/Maintenance:	Approved By:	Next inspection due:
	Date:	
Corrective Action/Maintenance:	Approved By:	Next inspection due:
	Date:	
Corrective Action/Maintenance:	Approved By:	Next inspection due:
	Date:	
Corrective Action/Maintenance:	Approved By:	Next inspection due:
	Date:	
Corrective Action/Maintenance:	Approved By:	Next inspection due:
	Date:	
Corrective Action/Maintenance:	Approved By:	Next inspection due:
	Date:	
Corrective Action/Maintenance:	Approved By:	Next inspection due:
	Date:	
Corrective Action/Maintenance:	Approved By:	Next inspection due:
	Date:	
Corrective Action/Maintenance:	Approved By:	Next inspection due:
	Date:	
Corrective Action/Maintenance:	Approved By:	Next inspection due:
	Date:	
Corrective Action/Maintenance:	Approved By:	Next inspection due:
	Date:	

1 Competent Person: One who is capable of identifying existing and predictable hazards in the surroundings or working conditions which are unsanitary, hazardous, or dangerous to employees, and who has authorization to take prompt corrective measures to eliminate them.

GLOBAL PRODUCT WARRANTY, LIMITED REMEDY AND LIMITATION OF LIABILITY

WARRANTY: THE FOLLOWING IS MADE IN LIEU OF ALL WARRANTIES OR CONDITIONS, EXPRESS OR IMPLIED, INCLUDING THE IMPLIED WARRANTIES OR CONDITIONS OF MERCHANTABILITY OR FITNESS FOR A PARTICULAR PURPOSE.

Unless otherwise provided by local laws, 3M fall protection products are warranted against factory defects in workmanship and materials for a period of one year from the date of installation or first use by the original owner.

LIMITED REMEDY: Upon written notice to 3M, 3M will repair or replace any product determined by 3M to have a factory defect in workmanship or materials. 3M reserves the right to require product be returned to its facility for evaluation of warranty claims. This warranty does not cover product damage due to wear, abuse, misuse, damage in transit, failure to maintain the product or other damage beyond 3M's control. 3M will be the sole judge of product condition and warranty options.

This warranty applies only to the original purchaser and is the only warranty applicable to 3M's fall protection products. Please contact 3M's customer service department in your region for assistance.

LIMITATION OF LIABILITY: TO THE EXTENT PERMITTED BY LOCAL LAWS, 3M IS NOT LIABLE FOR ANY INDIRECT, INCIDENTAL, SPECIAL OR CONSEQUENTIAL DAMAGES INCLUDING, BUT NOT LIMITED TO LOSS OF PROFITS, IN ANY WAY RELATED TO THE PRODUCTS REGARDLESS OF THE LEGAL THEORY ASSERTED.



Fall Protection

USA

3833 SALA Way
Red Wing, MN 55066-5005
Toll Free: 800.328.6146
Phone: 651.388.8282
Fax: 651.388.5065
3Mfallprotection@mmm.com

Brazil

Rodovia Anhanguera, km 110
Sumaré - SP
CEP: 13181-900
Brasil
Phone: 0800-013-2333
falecoma3m@mmm.com

Mexico

Av. Santa Fe No. 190
Col. Santa Fe, Ciudad de Mexico
CP 01219, Mexico
Phone: 01 800 120 3636
3msaludocupacional@mmm.com

Canada

600 Edwards Blvd, Unit #2
Mississauga, ON L5T 2V7
Phone: 905.795.9333
Toll-Free: 800.387.7484
Fax: 888.387.7484
3Mfallprotection-ca@mmm.com

EMEA (Europe, Middle East, Africa)

EMEA Headquarters:
Le Broc Center
Z.I. 1re Avenue - BP15
06511 Carros Le Broc Cedex
France
Phone: + 33 04 97 10 00 10
Fax: + 33 04 93 08 79 70
informationfallprotection@mmm.com

Australia & New Zealand

137 McCredie Road
Guildford
Sydney, NSW, 2161
Australia
Toll-Free : 1800 245 002 (AUS)
Toll-Free : 0800 212 505 (NZ)
3msafetyau@mmm.com

Asia

Singapore:
1 Yishun Avenue 7
Singapore 768923
Phone: +65-6450 8888
Fax: +65-6552 2113
TotalFallProtection@mmm.com

China:

38/F, Maxdo Center, 8 Xing Yi Rd
Shanghai 200336, P R China
Phone: +86 21 62753535
Fax: +86 21 52906521
3MFallProtection-CN@mmm.com

Korea:

3M Korea Ltd
20F, 82, Uisadang-daero,
Yeongdeungpo-gu, Seoul
Phone: +82-80-033-4114
Fax: +82-2-3771-4271
TotalFallProtection@mmm.com

Japan:

3M Japan Ltd
6-7-29, Kitashinagawa, Shinagawa-ku, Tokyo
Phone: +81-570-011-321
Fax: +81-3-6409-5818
psd.jp@mmm.com

WEBSITE:
3M.com/FallProtection



EU DECLARATION OF CONFORMITY:
3M.com/FallProtection/DOC