

KOMATSU®

PC18MR-3
PC27MR-3
PC35MR-3
PC55MR-3

PC20MR-3
PC30MR-3
PC45MR-3

OPERATING WEIGHT

PC18MR-3	1,780 kg	3,920 lb
PC20MR-3	2,160 kg	4,760 lb
PC27MR-3	2,890 kg	6,370 lb
PC30MR-3	3,140 kg	6,920 lb
PC35MR-3	3,580 kg	7,890 lb
PC45MR-3	4,760 kg	10,490 lb
PC55MR-3	5,160 kg	11,380 lb



Photos may include optional equipment

COMPACT
HYDRAULIC EXCAVATOR

WALK-AROUND



Performance and Versatility

- Komatsu HydrauMind hydraulic system
- Automatic load sensing two-speed travel
- Standard auxiliary hydraulics
- Integrated counterweight and tight tail swing

Operator Comfort

- Large operator platform
- Pilot proportional joystick controls
- Large monitor panel
- Easy entry and egress
- Low noise

Service and Maintenance

- Wide opening engine hood and side covers
- Side-by-side radiator and oil cooler are easy to inspect and clean.
- Extended lubrication and engine oil replacement intervals reduce maintenance and down time.
- Tilt-forward operator's station provides full access to engine.



OPERATING WEIGHT

PC18MR-3	1,780 kg	3,920 lb
PC20MR-3	2,160 kg	4,760 lb
PC27MR-3	2,890 kg	6,370 lb
PC30MR-3	3,140 kg	6,920 lb
PC35MR-3	3,580 kg	7,890 lb
PC45MR-3	4,760 kg	10,490 lb
PC55MR-3	5,160 kg	11,380 lb

Value, Durability, and Strength

- High strength X-track frame
- Castings are used for boom foot, tip, and swing yoke.
- Single large diameter swing pin
- Three track options: rubber, steel, and Roadliner
- O-ring face seal hydraulic fittings
- Moisture/dust resistant electrical connectors.

General Features

- Two-post ROPS canopy or ROPS cab
ROPS (ISO 3471) : Roll-Over Protective Structure
- Neutral engine start system
- Excellent visibility enhances job site awareness.
- Low emission Komatsu engine with dual element air cleaner
- One key operates the ignition and all machine locks.

PRODUCTIVITY FEATURES

Tight Tail Swing

Operator is able to focus on the work in front of them and worry less about a rear swing impact, even in confined areas with only an **80mm 3"** projection over the tracks.



Closed-center Load Sensing System (CLSS) HydraMind Hydraulic System

When two or more actuators are operated simultaneously, the pressure-compensated CLSS system ensures each actuator works according to its control input, regardless of the size of the load. This gives the operator precise control at all times.

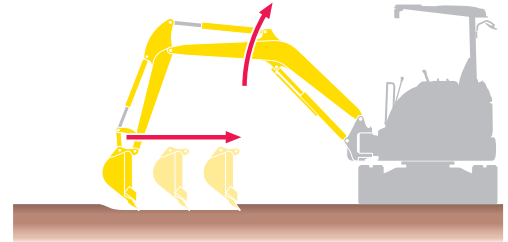

Confined Job Site Advantage

Operator can focus on digging and improve productivity, because they can worry less about obstacles to the rear of the machine, such as parked cars, walls and trees.

PC18MR-3	2,070mm	6'9"
PC20MR-3	2,250mm	7'5"
PC27MR-3	2,515mm	8'3"
PC30MR-3	2,415mm	7'11"
PC35MR-3	2,550mm	8'4"
PC45MR-3	2,830mm	9'3"
PC55MR-3	2,800mm	9'2"

* : When boom swing

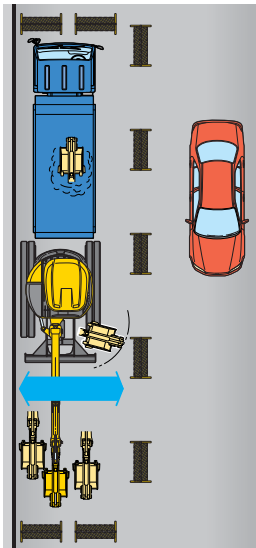

Automatic Two-speed Travel

The travel speed selector switch installed on the blade control allows the operator to engage high speed travel. Once engaged the system automatically senses the travel load and shifts between high speed and low speed travel.



Expandable Undercarriage (PC18MR-3)

The PC18MR-3 can pass through narrow space due to narrow width and undercarriage can be expanded for good stability during excavation.

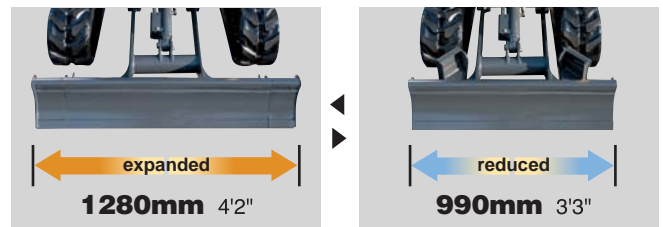

Working Ranges

	mm ft.in.			
	PC18MR-3	PC20MR-3	PC27MR-3	PC30MR-3
Max. digging height	3615 11'10"	4000 13'1"	4480 14'8"	4840 15'11"
Max. digging depth	2160 7'1"	2280 7'6"	2550 8'4"	2760 9'1"
Max. digging reach at ground level	3935 12'11"	4000 13'1"	4550 14'11"	4910 16'1"
Loading height	1220 4'0"	1430 4'8"	1650 5'5"	1700 5'7"

	PC35MR-3	PC45MR-3	PC55MR-3
Max. digging height	5000 16'5"	5515 18'1"	5945 19'6"
Max. digging depth	3110 10'2"	3350 12'0"	3800 12'6"
Max. digging reach at ground level	5170 17'0"	5575 18'3"	6070 19'11"
Loading height	1805 5'11"	1945 6'5"	1930 6'4"

Digging Force

	kg lb			
	PC18MR-3	PC20MR-3	PC27MR-3	PC30MR-3
Max. crowd force: Arm	1010 2230	1390 3065	1500 3310	1800 3970
Max. digging force: Bucket	1620 3570	1920 4235	2230 4920	3000 6610

	PC35MR-3	PC45MR-3	PC55MR-3
Max. crowd force: Arm	2100 4630	2200 4850	2440 5380
Max. digging force: Bucket	3050 6720	3460 7630	3980 8770

Auxiliary Flow

	L/min USgal/min			
	PC18MR-3	PC20MR-3	PC27MR-3	PC30MR-3
Auxiliary flow	35 9.2	35 9.2	50 13.2	50 13.2

	PC35MR-3	PC45MR-3	PC55MR-3
Auxiliary flow	60 15.8	70 18.5	70 18.5

Drawbar Pull

	kg lb			
	PC18MR-3	PC20MR-3	PC27MR-3	PC30MR-3
Max. drawbar pull	1700 3750	2060 4540	3200 7050	3400 7500

	PC35MR-3	PC45MR-3	PC55MR-3
Max. drawbar pull	3400 7500	4280 9440	4280 9440

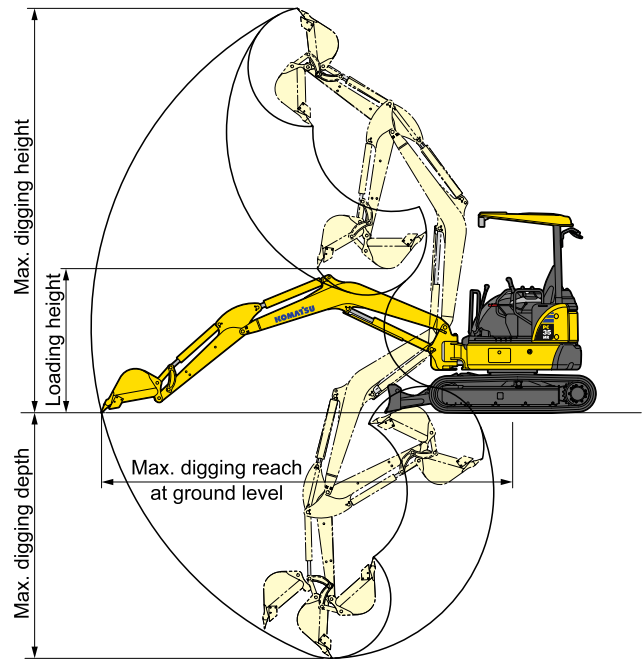

Stability

The MR-3 series offers exceptional lifting capacity and stability in a tight tail machine.

Lifting capacity comparison

	kg lb			
	PC18MR-3	PC20MR-3	PC27MR-3	PC30MR-3
3m 10'	220 480	285 630	370 820	365 800
Rating at max. reach	185 410	240 530	245 540	220 480

	PC35MR-3	PC45MR-3	PC55MR-3
3m 10'	580 1280	995 2190	1005 2220
Rating at max. reach	345 760	505 1110	435 960

The conditions of this comparison are a standard arm, sideways, blade on ground, and at a height of 0m (Ground level).

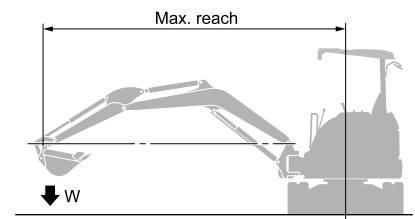

OPERATOR ENVIRONMENT

Large Entrance and Foot Space

The two-post canopy design allows the MR-3 series to have larger entrance for entry and egress.



Fully Adjustable Operator's Seat

The spacious operator's compartment provides outstanding ride quality. The large operator's seat enhances operator comfort.

Joystick Controls

Pressure Proportional Control (PPC) joystick controls are low effort and provide fine control.



PC18MR-3

Excellent Visibility

The operator's station design allows the operator to maintain 360° field view.



Pattern Change Valve (Optional Equipment)

Pattern change valve allows the operator to change easily between ISO control pattern (ISO 10968) or backhoe control pattern.



Large Operator's Cab (Optional Equipment) (Not Available for PC18MR-3)

The cab provides outstanding foot space. Ergonomic design helps reduce fatigue. The large rear glass provides the operator excellent rear visibility.



Upper-rail Type Sliding Door



Large Rear Glass



Large-capacity Air Conditioner (Optional Equipment) (Not Available for PC20MR-3)

Provides comfortable operator environment throughout the year.



Cup Holder

Large cup holder is standard equipment.



EASY MAINTENANCE

Tilt-up Operator Compartment

Operator's compartment floor tilts forward providing easy access to hydraulic compartments.

Fully Opening Engine Door and Side Cover

Allow easy access for daily checks and regular maintenance.



High Strength X-track Frame

X-track frame is a large hydraulic excavator concept and deters dirt and debris build up saving the operator valuable time when cleaning the machine.

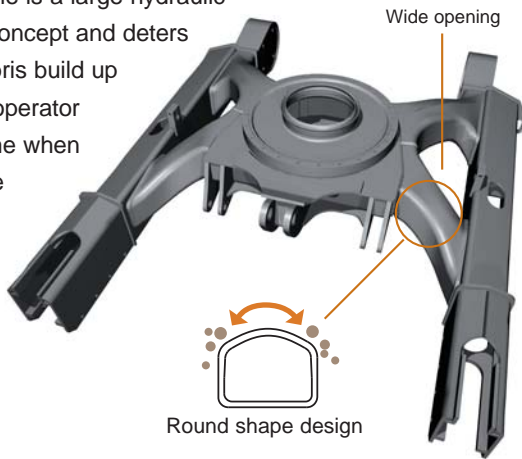

Larger Diameter Swing Pin

Has high durability and maintains suitable clearances between pin and bushing after long-term operation.



Sealed Connector

Sealed connectors are moisture and dust resistant.

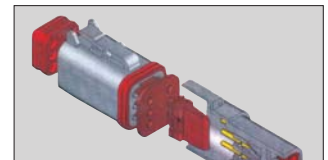

O-ring Face Seal

O-ring face seals are highly reliable.

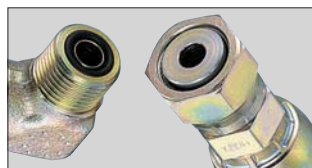

GENERAL FEATURES

Two-post ROPS & OPG Canopy

ROPS (ISO 3471) [Roll-Over Protective Structure]

This canopy meets the requirements of ROPS, with the advantage of a two-post design.



Tie-Downs or Anchor Points

Large tie-downs or anchor points in the track frame and blade allow the machine to be secured quickly for transport.



Chevron-shaped Boom Cylinder Guard and Boom Bottom Working Lamp (Not Available for PC18MR-3 and PC27MR-3)

A chevron-shaped boom cylinder guard* is provided

This design reduces damage to the cylinder caused by interference of the breaker, hitting against the dump vessel, etc.

* The boom cylinder guard of the PC20MR-3 is a reinforced thick plate type.

A working lamp is provided on the boom bottom

A working lamp for work equipment is provided on the boom bottom to prevent damage due to accidental contact.



A Travel Lamp Is Provided Near of Operator's Seat as the Standard Equipment (Not Available for PC18MR-3 and PC27MR-3)

This travel lamp provides an increased visibility both in a night operation and in the travel position.



Neutral Engine Start System

Locks out drives and hydraulics during machine start up.

OPTIONAL EQUIPMENT

Roadliner (Not Available for PC18MR-3 and PC20MR-3)

Replacement is fast, easy and cost efficient as individual shoes are replaced when damaged or worn instead of replacing the entire track.



Steel Shoes with Rubber Pad



Optional Blade

(Bolt-On Cutting edge (B.O.C.) type)



Power Angle Blade (Not Available for PC18MR-3, PC20MR-3 and PC27MR-3)

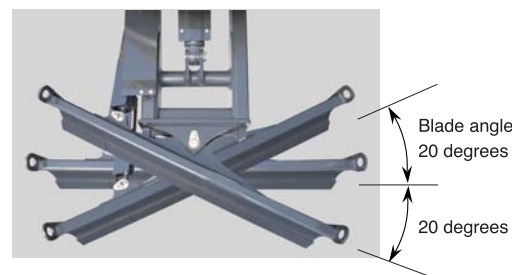

MR-3 SERIES COMPACT HYDRAULIC EXCAVATOR

SPECIFICATIONS

		PC18MR-3	PC20MR-3	PC27MR-3	PC30MR-3	PC35MR-3	PC45MR-3	PC55MR-3	
Performance	Operating weight	kg lb	1780 3920	2160 4760	2890 6370	3140 6920	3580 7890	4760 10490	5160 11380
			ROPS Canopy, Rubber Shoe	ROPS Canopy, Rubber Shoe	ROPS Canopy, Rubber Shoe	ROPS Canopy, Rubber Shoe	ROPS Canopy, Rubber Shoe	ROPS Canopy, Rubber Shoe	ROPS Canopy, Rubber Shoe
	Flywheel horsepower	kW/min ⁻¹ HP/min ⁻¹	11.2/2600 15/2600	15.5/2500 20.8/2500	19.2/2600 25.7/2600	21.4/2400 28.6/2400	21.4/2400 28.6/2400	28.5/2400 38.2/2400	28.5/2400 38.2/2400
	Bucket capacity (ISO 7451 heaped) (CECE heaped)	m ³ yd ³	0.044 0.058 0.04 0.052	0.066 0.086 0.06 0.08	0.08 0.10 0.07 0.09	0.09 0.12 0.08 0.10	0.11 0.14 0.10 0.13	0.14 0.18 0.13 0.17	0.16 0.21 0.14 0.18
	Bucket width (incl. side cutters)	mm in	400 16 450 18	430 17 500 20	430 17 500 20	430 17 500 20	530 21 600 24	530 21 600 24	580 23 650 26
	Travel speed	Hi	km/h MPH	4.3 2.7	4.6 2.9	4.8 3.0	4.6 2.9	4.8 3.0	4.6 2.9
		Lo	km/h MPH	2.3 1.4	2.8 1.7	2.6 1.6	2.5 1.6	2.8 1.7	2.8 1.7
	Swing speed	min ⁻¹	8.9	8.9	9.2	9.3	9	9	9
	Ground pressure	kg/cm ² PSI	0.32 4.6	0.27 3.9	0.32 4.6	0.30 4.3	0.36 5.1	0.25 3.6	0.29 4.1
	Max. traction force	kg lb	1700 3750	2060 4540	3200 7050	3400 7500	3400 7500	4280 9440	4280 9440
Engine	Gradeability	deg.	30	30	30	30	30	30	
	Bucket digging force (ISO 6015)	kg lb	1620 3570	1920 4230	2230 4920	3000 6610	3050 6720	3460 7630	3980 8770
	Arm crowd force (ISO 6015)	kg lb	1010 2230	1390 3065	1500 3310	1800 3970	2100 4630	2200 4850	2440 5380
	Model	—	Komatsu 3D67E-2	Komatsu 3D76E-6	Komatsu 3D82AE-6	Komatsu 3D88E-6	Komatsu 3D88E-6	Komatsu 4D88E-6	Komatsu 4D88E-6
	Type	—	Swirl chamber	Swirl chamber	Direct injection	Direct injection	Direct injection	Direct injection	Direct injection
Electric System	Piston displacement	L in ³	0.778 47	1.115 68	1.33 81	1.642 100	1.642 100	2.189 134	2.189 134
	Operation voltage	V	12	12	12	12	12	12	
	Battery	Ah	41	45	58	58	58	72	
	Alternator	A	40	40	40	40	40	40	
Blade	Starter	kW	1.2	1.4	2.3	2.3	2.3	2.3	
	Width x height	mm ft.in.	990 or 1280 x 250 3'3" or 4'2" x 10"	1450 x 300 4'9" x 1'0"	1550 x 355 5'1" x 1'2"	1550 x 355 5'1" x 1'2"	1740 x 355 5'9" x 1'2"	1960 x 355 6'5" x 1'2"	1960 x 355 6'5" x 1'2"
Drive System	Drive method	—	Hydrostatic	Hydrostatic	Hydrostatic	Hydrostatic	Hydrostatic	Hydrostatic	
	Type of travel brake	—	Hydraulic lock type	Hydraulic lock type	Hydraulic lock type	Hydraulic lock type	Hydraulic lock type	Hydraulic lock type	
	Type of travel shoe	—	Rubber	Rubber	Rubber	Rubber	Rubber	Rubber	
Undercarriage	Adjustment of the track tension	—	Grease	Grease	Grease	Grease	Grease	Grease	
	Number of shoes (For each side)	—	35 (steel)	39 (steel)	40 (steel)	44 (steel)	44 (steel)	39 (steel)	
	Number of carrier rollers (For each side)	—	0	0	1	1	1	1	
	Number of track rollers (For each side)	—	3	3	4	4	4	4	
Hydraulic System	Type of hydraulic pump	—	Variable capacity x 1 gear x 1	Variable capacity x 1 gear x 1	Variable capacity x 1 gear x 1	Variable capacity x 1 gear x 1	Variable capacity x 2 gear x 1	Variable capacity x 2 gear x 1	
	Max. oil flow	L/min USgal/min	41.6 x 1 + 12.7 11.0 x 1 + 3.4	53.4 x 1 + 15.5 14.1 x 1 + 4.1	70.6 x 1 + 21.4 18.7 x 1 + 5.7	69.8 x 1 + 19.8 18.4 x 1 + 5.2	36.1 x 2 + 19.8 9.5 x 2 + 5.2	53.5 x 2 + 33.8 14.1 x 2 + 8.9	53.5 x 2 + 33.8 14.1 x 2 + 8.9
	Hydraulic motor (Travel)	—	Variable capacity x 2	Variable capacity x 2	Variable capacity x 2	Variable capacity x 2	Variable capacity x 2	Variable capacity x 2	
	(Swing)	—	fixed capacity x 1	fixed capacity x 1	fixed capacity x 1	fixed capacity x 1	fixed capacity x 1	fixed capacity x 1	
	Max. pressure setting	kg/cm ² PSI	235 3340	250 3560	250 3560	265 3770	265 3770	270 3840	270 3840
Refilling Capacity	Auxiliary hydraulic flow	L/min USgal/min	35 9.2	35 9.2	50 13.2	50 13.2	60 15.8	70 18.5	70 18.5
	Fuel tank	L USgal	19 5.0	28 7.4	44 11.6	44 11.6	44 11.6	65 17.2	65 17.2
	Hydraulic tank	L USgal	15.2 4.0	19 5.0	14 3.7	14 3.7	14 3.7	20 5.3	20 5.3
	Engine	L USgal	3.3 0.9	3.4 0.9	5 1.3	6.7 1.8	6.7 1.8	7.5 2.0	7.5 2.0
Coolant	L USgal	3.1 0.8	3.0 0.8	3.3 0.9	3.3 0.9	3.3 0.9	8.5 2.2	8.5 2.2	

WORKING RANGE

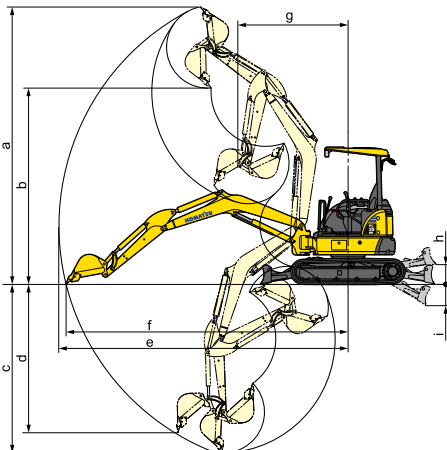

Standard Arm Working Range

	PC18MR-3	PC20MR-3	PC27MR-3	PC30MR-3	PC35MR-3	PC45MR-3	PC55MR-3
a Max. digging height	mm ft.in.	3615 11'10"	4000 13'1"	4480 14'8"	4840 15'11"	5000 16'5"	5515 18'1"
b Max. dumping height	mm ft.in.	2610 8'7"	2760 9'1"	3190 10'6"	3350 11'0"	3530 11'7"	3785 12'5"
c Max. digging depth	mm ft.in.	2160 7'1"	2280 7'6"	2550 8'4"	2760 9'1"	3110 10'2"	3350 11'0"
d Max. vertical digging depth	mm ft.in.	1785 5'10"	1860 6'1"	2080 6'10"	2400 7'10"	2690 8'10"	2645 8'8"
e Max. digging reach	mm ft.in.	4025 13'2"	4150 13'7"	4650 15'3"	5050 16'7"	5300 17'5"	5735 18'10"
f Max. digging reach at ground level	mm ft.in.	3935 12'11"	4000 13'1"	4550 14'11"	4910 16'1"	5170 17'0"	5575 18'3"
g Min. swing radius (When boom swing)	mm ft.in.	1670 5'6"	1790 5'10"	1980 6'6"	2055 6'9"	2030 6'8"	2340 7'8"
	mm ft.in.	(1355 4'5")	(1450 4'9")	(1660 5'5")	(1560 5'1")	(1600 5'3")	(1770 5'10")
h Max. blade lift	mm ft.in.	280 1'1"	340 1'1"	360 1'2"	360 1'2"	360 1'2"	430 1'5"
i Max. blade depth	mm ft.in.	255 10"	240 9'4"	310 1'0"	310 1'0"	390 1'3"	330 1'1"

Long Arm Working Range

	PC18MR-3	PC20MR-3	PC27MR-3	PC30MR-3	PC35MR-3	PC45MR-3	PC55MR-3
a Max. digging height	mm ft.in.	3820 12'6"	4300 14'1"	4690 15'5"	5070 16'8"	5270 17'3"	5780 19'0"
b Max. dumping height	mm ft.in.	2815 9'3"	3020 9'11"	3390 11'1"	3580 11'9"	3790 12'5"	4060 13'4"
c Max. digging depth	mm ft.in.	2410 7'11"	2580 8'6"	2840 9'4"	3130 10'3"	3455 11'4"	3770 12'4"
d Max. vertical digging depth	mm ft.in.	2000 6'7"	2215 7'3"	2370 7'9"	2770 9'1"	3120 10'3"	3060 10'0"
e Max. digging reach	mm ft.in.	4270 14'0"	4500 14'9"	4930 16'2"	5390 17'8"	5640 18'6"	6130 20'1"
f Max. digging reach at ground level	mm ft.in.	4190 13'9"	4350 14'3"	4840 15'11"	5215 17'1"	5520 18'1"	5980 19'7"
g Min. swing radius (When boom swing)	mm ft.in.	1770 5'10"	1940 6'4"	2030 6'8"	2190 7'2"	2140 7'0"	2410 7'11"
	mm ft.in.	(1435 4'8")	(1515 5'0")	(1700 5'7")	(1665 5'6")	(1710 5'7")	(1860 6'1")
h Max. blade lift	mm ft.in.	280 1'1"	340 1'1"	360 1'2"	360 1'2"	360 1'2"	430 1'5"
i Max. blade depth	mm ft.in.	255 10"	240 9'4"	310 1'0"	310 1'0"	390 1'3"	330 1'1"

DIMENSIONS

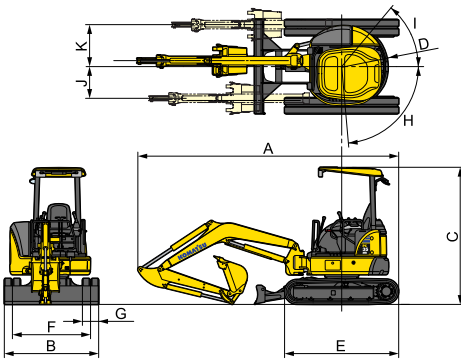

		PC18MR-3	PC20MR-3	PC27MR-3	PC30MR-3	PC35MR-3	PC45MR-3	PC55MR-3
A	Overall length mm ft.in.	3650 12'0"	3750 12'4"	4240 13'11"	4560 15'0"	4825 15'10"	5220 17'2"	5550 18'3"
B	Overall width mm ft.in.	1280 4'2"	1450 4'9"	1550 5'1"	1550 5'1"	1740 5'9"	1960 6'5"	1960 6'5"
C	Overall height mm ft.in.	2410 7'11"	2520 8'3"	2520 8'3"	2520 8'3"	2520 8'3"	2550 8'4"	2550 8'4"
D	Tail swing radius mm ft.in.	715 2'4"	805 2'8"	855 2'10"	855 2'10"	950 3'1"	1060 3'6"	1060 3'6"
E	Crawler length mm ft.in.	1555 5'1"	1880 6'2"	1950 6'5"	2105 6'11"	2105 6'11"	2520 8'3"	2520 8'3"
F	Track gauge mm ft.in.	1045 3'5"	1200 3'11"	1250 4'1"	1250 4'1"	1440 4'9"	1560 5'1"	1560 5'1"
G	Track shoe width mm in.	230 9"	250 9.8"	300 12"	300 12"	300 12"	400 16"	400 16"
H/I	Boom swing angle deg.	LH70/RH50	LH75/RH50	LH85/RH50	LH80/RH50	LH75/RH55	LH85/RH50	LH85/RH50
J	Bucket offset LH mm ft.in.	465 1'6"	510 1'8"	580 1'11"	580 1'11"	580 1'11"	630 2'1"	630 2'1"
K	Bucket offset RH mm ft.in.	785 2'7"	760 2'6"	845 2'9"	845 2'9"	770 2'6"	880 2'11"	880 2'11"

LIFTING CAPACITY

Blade on Ground (With additional counterweight (X-weight) for PC18MR-3 and PC20MR-3)

Unit: kg lb

Model	Arm Length		2m 6.5'		3m 10'		Maximum					
			Front	Side	Front	Side	Front	Side				
PC18MR-3	965mm 3'2"	3m 10'					*355	*780	*355	*780		
		2m 6.5'					*315	*700	215	470		
		1m 3.25'	*650	*1435	420	930	*365	*810	230	510	*320	*710
		0m 0'	*805	*1780	395	870	*410	*900	220	480	*335	*740
		-1m -3.25'	*635	*1400	400	880			*340	*750	245	540
		0m 0'	*795	*1750	390	860	*400	*880	215	470	*300	*660
PC20MR-3	970mm 3'2"	3m 10'					*515	*1135	375	825		
		2m 6.5'					*545	*1200	250	550		
		1m 3.25'	*1310	*2885	550	1215	*685	*1510	295	650	*595	*1310
		0m 0'	*1535	*3385	530	1170	*790	*1745	285	630	*655	*1445
		-1m -3.25'	*1260	*2780	545	1200			*740	*1630	345	760
		0m 0'	*1495	*3295	515	1135	*750	*1655	275	605	*555	*1220
PC27MR-3	1100mm 3'7"	3m 10'					*650	*1430	425	940		
		2m 6.5'					*795	*1750	410	900		
		1m 3.25'	*1215	*2680	800	1760	*1065	*2350	385	850	*735	*1620
		0m 0'	*2230	*4920	680	1500	*1185	*2610	370	820	*775	*1710
		-1m -3.25'	*1820	*4010	695	1530	*1020	*2250	370	820	*810	*1790
		0m 0'	*2305	*5080	660	1450	*1155	*2550	355	780	*695	*1530
PC30MR-3	1240mm 4'1"	3m 10'					*795	*1750	435	960		
		2m 6.5'					*1000	*2200	420	930		
		1m 3.25'					*1320	*2910	385	850		
		0m 0'	*2660	*5860	680	1500	*1440	*3170	365	800	*870	*1920
		-1m -3.25'	*2140	*4720	695	1530	*1250	*2760	365	800	*880	*1940
		0m 0'	*2820	*6220	670	1480	*1415	*3120	360	790	*780	*1720
PC35MR-3	1370mm 4'6"	3m 10'					*705	*1550	680	1500		
		2m 6.5'					*960	*2120	655	1440		
		1m 3.25'					*1290	*2840	610	1350		
		0m 0'	*2610	*5750	1100	2420	*1430	*3150	580	1280	*885	*1950
		-1m -3.25'	*2245	*4950	1120	2470	*1325	*2920	580	1280	*920	*2030
		0m 0'	*2735	*6030	1085	2390	*1390	*3060	575	1270	*720	*1590
PC45MR-3	1375mm 4'6"	3m 10'					*990	*2180	*990	*2180	*1020	*2250
		2m 6.5'					*1530	*3370	1100	2430	*1060	*2340
		1m 3.25'					*2125	*4690	1025	2260	*1120	*2470
		0m 0'					*2345	*5170	995	2190	*1195	*2640
		-1m -3.25'	*3010	*6640	1965	*4330	*2195	*4840	995	2190	*1280	*2820
		0m 0'	*1250	*2760	*1250	*2760	*2275	*5020	980	2160	*1045	*2300
PC55MR-3	1640mm 5'5"	3m 10'					*1435	*3160	1140	2510	*885	*1950
		2m 6.5'					*2030	*4480	1045	2300	*930	*2050
		1m 3.25'					*2260	*4980	1005	2220	*985	*2170
		0m 0'					*2170	*4780	1000	2200	*1050	*2320
		-1m -3.25'	*2790	*6150	1960	*4320						
		0m 0'	*1285	*2830	*1285	*2830	*2205	*4860	1010	2230	*895	*1970

*Load is limited by hydraulic capacity rather than tipping. Rated loads do not exceed 87% of hydraulic capacity or 75% of tipping load.

STANDARD/OPTIONAL EQUIPMENT

●: Standard equipment ○: Optional equipment

	PC18MR-3	PC20MR-3	PC27MR-3	PC30MR-3	PC35MR-3	PC45MR-3	PC55MR-3
Arm							
Standard arm with aux. piping							
PC18MR: 965mm 3'2"	●	●	●	●	●	●	●
PC27MR: 1100mm 3'7"							
PC35MR: 1370mm 4'6"							
PC45MR: 1375mm 4'6"							
PC55MR: 1640mm 5'5"							
Long arm with aux. piping							
PC18MR: 1215mm 4'0"	○	○	○	○	○	○	○
PC20MR: 1320mm 4'4"							
PC27MR: 1410mm 4'8"							
PC30MR: 1610mm 5'3"							
PC35MR: 1720mm 5'8"							
PC45MR: 1770mm 5'10"							
PC55MR: 2000mm 6'7"							
Standard arm without aux. piping	○	○	○	○	○	○	○
Long arm without aux. piping	○	○	○	○	○	○	○
Bucket Capacity Bucket width (Incl. side cutters)							
0.022m ³ 0.029yd ³ 250mm 10" (300mm 12")	○						
0.033m ³ 0.043yd ³ 250mm 10" (320mm 13")		○					
0.035m ³ 0.046yd ³ 250mm 10" (320mm 13")			○				
0.04m ³ 0.052yd ³ 350mm 14" (400mm 16")	○			○			
0.044m ³ 0.058yd ³ 280mm 11" (350mm 14")				○	○		
0.044m ³ 0.058yd ³ 350mm 14" (420mm 17")		○	○				
0.044m ³ 0.058yd ³ 400mm 16" (450mm 18")	●						
0.055m ³ 0.072yd ³ 300mm 12" (370mm 14")						○	○
0.055m ³ 0.072yd ³ 350mm 14" (420mm 17")				○	○		
0.066m ³ 0.086yd ³ 430mm 17" (500mm 20")		●					
0.08m ³ 0.10yd ³ 430mm 17" (500mm 20")			●				
0.08m ³ 0.10yd ³ 530mm 21" (600mm 24")		○					
0.09m ³ 0.12yd ³ 430mm 17" (500mm 20")				●	○		
0.09m ³ 0.12yd ³ 530mm 21" (600mm 24")			○				
0.11m ³ 0.14yd ³ 430mm 17" (500mm 20")						○	○
0.11m ³ 0.14yd ³ 530mm 21" (600mm 24")				○	●		
0.13m ³ 0.17yd ³ 630mm 25" (700mm 28")					○		
0.14m ³ 0.18yd ³ 535mm 21" (600mm 24")						●	
0.16m ³ 0.21yd ³ 585mm 23" (650mm 26")						○	●
Track shoes							
230mm 9" rubber shoes	●						
250mm 10" rubber shoes		●					
300mm 12" rubber shoes			●	●	●		
400mm 16" rubber shoes						●	●
230mm 9" steel shoes	○						
250mm 10" steel shoes		○					
300mm 12" steel shoes			○	○	○		
400mm 16" steel shoes						○	○
230mm 9" steel shoes with rubber pad	○						
250mm 10" steel shoes with rubber pad		○					
300mm 12" steel shoes with rubber pad			○	○	○		
400mm 16" steel shoes with rubber pad						○	○
300mm 12" road liner			○	○	○		
400mm 16" road liner						○	○
Blade							
Expandable blade assembly	●						
Blade assembly		●	●	●	●	●	●
Blade assembly with B.O.C.		○	○	○	○	○	○
Power angle blade				○	○	○	○
Others							
Standard Equipment				Optional Equipment			
<ul style="list-style-type: none"> • Air cleaner, double element • Automatic two-speed travel • Rear view mirrors, RH and LH • Seat belt, 78mm 3" width • Steering pedals • Rigid seat, reclining with wrist rests • Travel alarm • Two-post ROPS (ISO 3471) & top guard canopy 				<ul style="list-style-type: none"> • Additional working light • Air conditioner (A/C) (For cab) (Not available for PC18MR-3 and PC20MR-3) • Cigarette lighter (For cab) • Pattern change valve (ISO - Backhoe) (ISO control pattern (ISO 10968)) • Radiator net • Radio (For cab) • Suspension seat, reclining with wrist rests • ROPS (ISO 3471) & top guard cab with heater, front window washer/wiper, cup holder and ashtray (Not available for PC18MR-3) • Seat belt, 50mm 2" width 			

B.O.C. : Bolt-On Cutting edge

www.komatsu.com

Printed in Japan 201610 IP.As



CEN00374-06

Materials and specifications are subject to change without notice.
KOMATSU is a trademark of Komatsu Ltd. Japan.